



HeatDefender[®] Patent Pending

The Professional Standard for Heat Trace Protection and Performance

Residential and Commercial Roof, Gutter, and Drain De-Icing



Engineered to house Raychem[®], Chromalox[®], Thermon[®] and other major self-regulating heat trace cables.

WWW.ALPINESNOWGUARDS.COM

Contents

General Information

Introduction	3
Testing	4
Use and Safety Guidelines	5
Components and Applications	6

Steep-Slope Layout Recommendations

Overview	7
Hardware and Wattage Recommendations	8
Cable Configurations	9
Bill of Materials	10

Steep Slope Installation Instructions

Low-Slope Layout Recommendations	
Overview	13
Kit Configurations	14

Low-Slope Installation Instructions

Technical Details	16
3 Part Specification	17

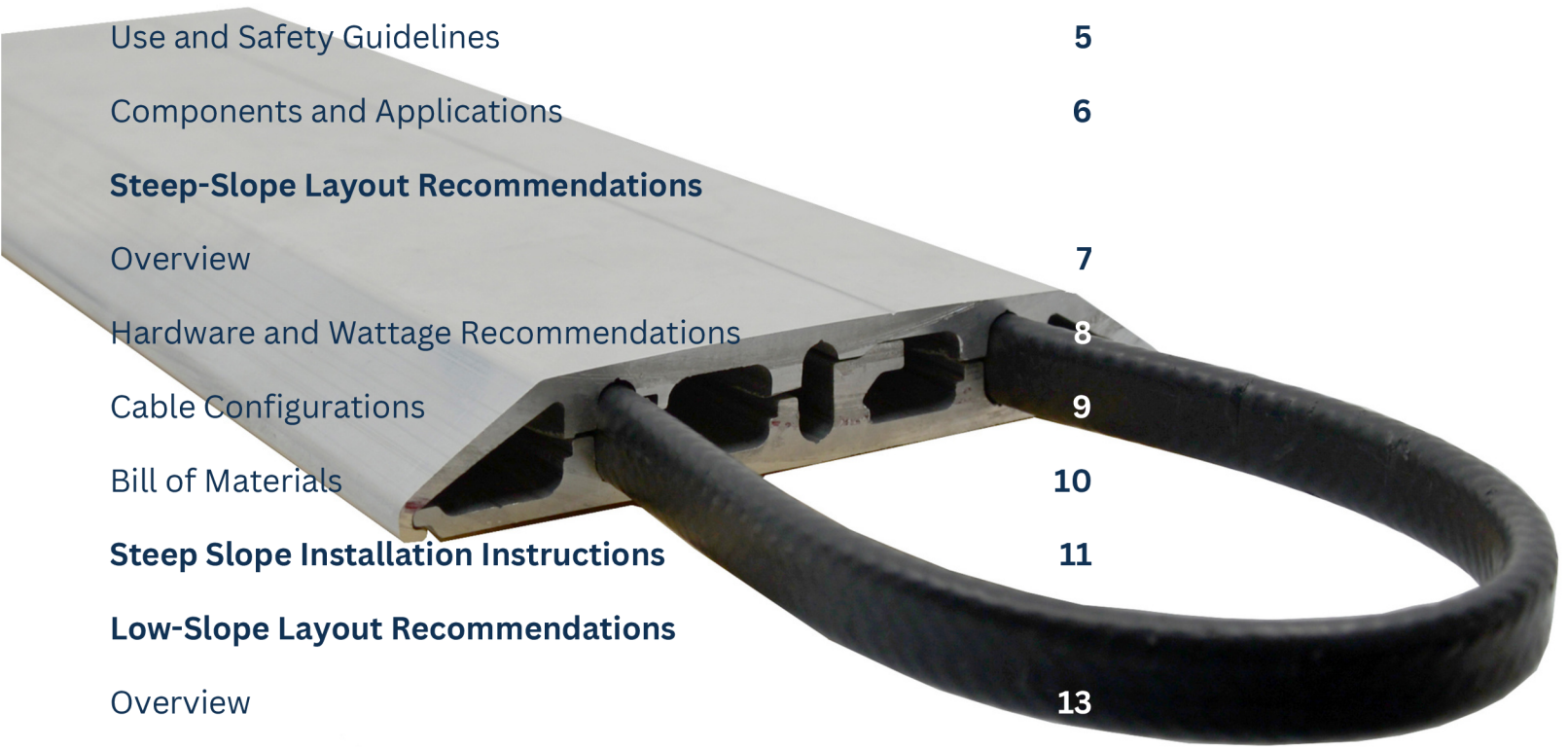

HeatDefender

HeatDefender is a heat cable housing that increases the efficiency and lifespan of rooftop heat trace cable. The HeatDefender's proprietary two-part aluminum extrusion (Patent Pending) increases the performance of rooftop heat trace cable while protecting it from environmental exposure. The HeatDefender will increase the meltwater area and maintain water exit channels, preventing ice dams from forming on the roof eave, in the valley, at the gutter, and at low-slope roof drains.

Assemblies available for:

- New and retrofit steep slope roofing, including eave, gutter, and valley applications
- Facades and internal roof drains
- External roof drains and scuppers (utilizing HeatDefender® DrainMelt™ kits)

All HeatDefender Assemblies offer:

- Increased efficiency of heat cable performance
- Protection for cable from environmental elements and physical hazards
- Optimized for high-efficiency thermal transfer



Thermal Radiator Performance. HS-800 system with Kynar-finished flashing. Note the consistent meltwater path and the total absence of ice accumulation at the drip edge, even during high-accumulation cycles. This demonstrates the superior heat distribution of the aluminum thermal transfer plate compared to traditional exposed cable.

Performance Validation

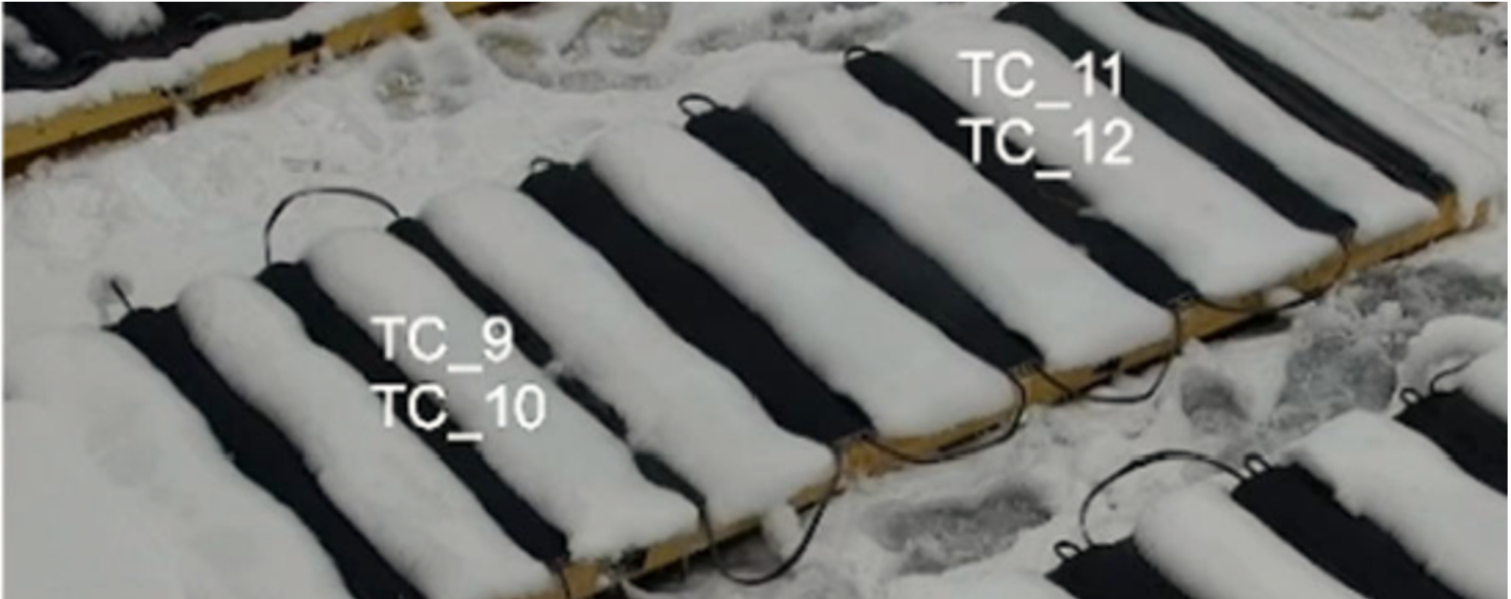

SIMULATED EXTREME ENVIRONMENT STRESS-TESTING

- To ensure absolute field reliability, HeatDefender roof mock-ups were subjected to simulated extreme winter cycles. Testing conducted by Microclimate Ice & Snow Inc. focused on thermal transfer efficiency in temperatures as low as -20°C (-4°F) and heavy, sustained snowfall.

TESTING PERFORMED BY

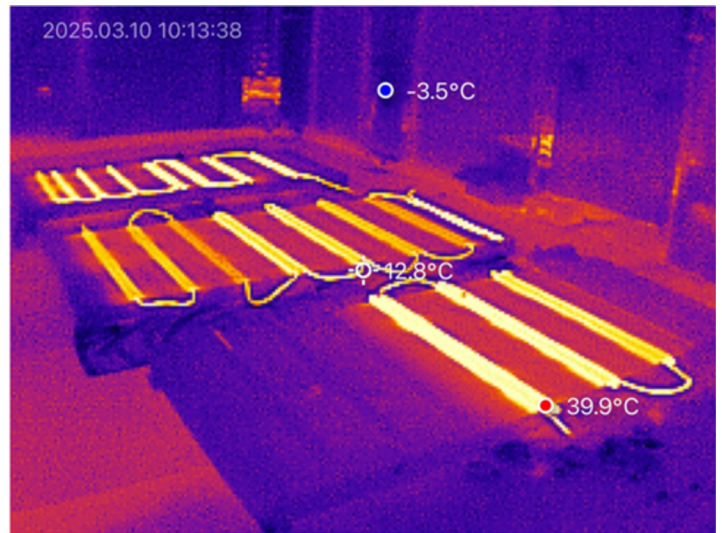

KEY FINDINGS

- Superior Heat Retention:** While exposed cable installations lose approximately 50% of their thermal energy to the surrounding air and wind, the HeatDefender's aluminum extrusion serves as a protective wind shelter and high-efficiency radiator to maximize heat transfer into the ice and snow.
- Scalable Power Output:** Data demonstrated that surviving extreme cold (-20°C) requires robust heat density. The HeatDefender is designed to utilize "Full Heat" multi-cable configurations (20–30 W/ft), providing the necessary power to maintain open melt paths and prevent freeze-overs in the most severe climates.
- Radiant Surface Area:** The aluminum housing captures and distributes heat across its entire width, significantly increasing the effective snow and ice melt area compared to exposed cable.
- Drainage Continuity:** In Zone IV (Extreme) environments, configurations of 20–30 W/ft were found essential to prevent the formation of hazardous ice dams.
- Systemic Reliability:** The HeatDefender maintains wider, more reliable drainage channels, ensuring a continuous warm water exit path from the roof to the landscape.
- Low-Slope Validation:** Spacing and layouts used for DrainMelt™ and scupper systems were validated to be extremely effective in melting snow and ice.

The HeatDefender is an engineered, cable-agnostic platform designed to maximize the lifespan and thermal efficiency of any major self-regulating heat trace cable, including systems by Raychem, Chromalox, and Thermon. By providing a protected, high-conductivity environment, HeatDefender allows cables to operate at peak performance even in ambient temperatures as low as -20°C (-4°F).

Getting Started

This manual outlines the installation and operation of the HeatDefender high-performance heat-trace enclosure. All safety and installation guidelines for the heat trace cable, connection kits, and controllers must be followed and obtained directly from the original manufacturer.

Design Information and Compatibility

The HeatDefender, a heat trace cable performance enhancing concealer system, mechanically fastens to the roof deck over and through existing roofing material at the eave. On eave applications, the roof's watertight integrity is maintained through a compression-fit seal at attachment points and/or cover flashing. Low slope and gutter applications can be adhered. HeatDefender components have been designed to accommodate Raychem GM-1X & GM-2X, Chromalox CPR8, CPR10 & CPR15, and Thermon heat trace cables.

- HeatDefender requires a self-regulating heating cable. A plug-in constant-watt heat trace cable is not acceptable.
- A self-regulating heating cable must be a two-conductor system, meaning that the end of the heating cable does not have to return to its start point. One-conductor cables are not acceptable for this application.
- A heating cable with an outer polyolefin jacket is required. Cables without an outer jacket are not for wet applications and, therefore, cannot be used in this application.
- The heating cable must allow the installer to cut to length in the field without developing cold zones. Heat trace cable systems that cannot be cut to length are unacceptable for this application.
- Self-regulating heating cable must be installed with a system controller capable of managing the length and wattage of heat trace cable used.

Safety Guidelines

Proper design, installation, and maintenance is required for the safety and reliability of any heating cable system. Incorrect installation of the HeatDefender system or any electrical component can cause overheating, underheating, damage to the system, electrical shock, or fire. All local and national electrical codes must be followed during cable and control installation for safety. Ground fault equipment must be used following heat trace cable manufacturer requirements.

Components & Applications

1-2. Two-part system (baseplate and snap-fit cover) for easy, efficient, and time-saving installation

3. Fastening points - mechanical and adhered fastening options

4. Three channels for heat cable - use up to three heat cables for maximum output

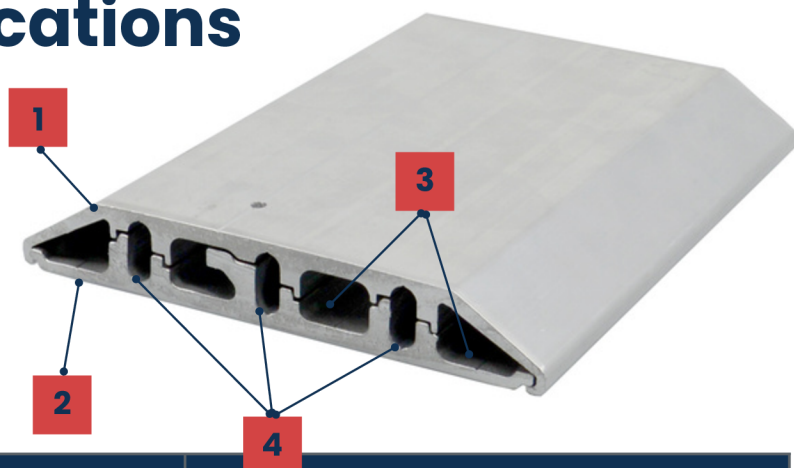

	Part Number	Applications	Description
	HS-800 (HS-801 Base and HS-802 Cover)	Steep Slope Roofing at Eave, Ledges	5" wide, two-part (base and cover) heat trace concealer that includes 3 channels for heat cable - can be used with up to 3 cables. Use with flashing or powder-coat.
	HS-700 (HS-701 Base and HS-702 Cover)	Gutter, Valley, Low-Slope Roof Drains & Scuppers (utilizing HS-700 components inside DrainMelt™ Kits)	3.125" wide, two-part (base and cover) heat trace concealer that includes 2 channels for heat cable. Use with flashing or powder-coat.
	HS-802-FL	Shingle Applications at Roof Eave	Kynar flashing can be used in new and retrofit applications on shingle roofs, at the eave.
	HS-803-C	Used to join HS-800 runs when flashing is not used	Coupling to join 6' HS-800 runs. Not required when system is flashed. Can be powder-coated.
	HS-800-END HOLLOW	Paired with HS-800 as a protected cable return	Cable Return Hollow. Used to protect and conceal cable loop at the full end of a run.
	HS-ENDCAP	End Cap for a HS-800 run	End Cap to close off system. End cap contains 3 holes for cable, holes can be closed off with plugs if not used.
	BUSHING B-100-S W-NEO SS-.25	Used when mechanically fastening HS-800 or HS-700	EPDM bushing and washer will accomplish a watertight compression fit seal when mechanically fastened to roof. Used with flashed and unflashed systems.

HeatDefender Steep Slope Applications

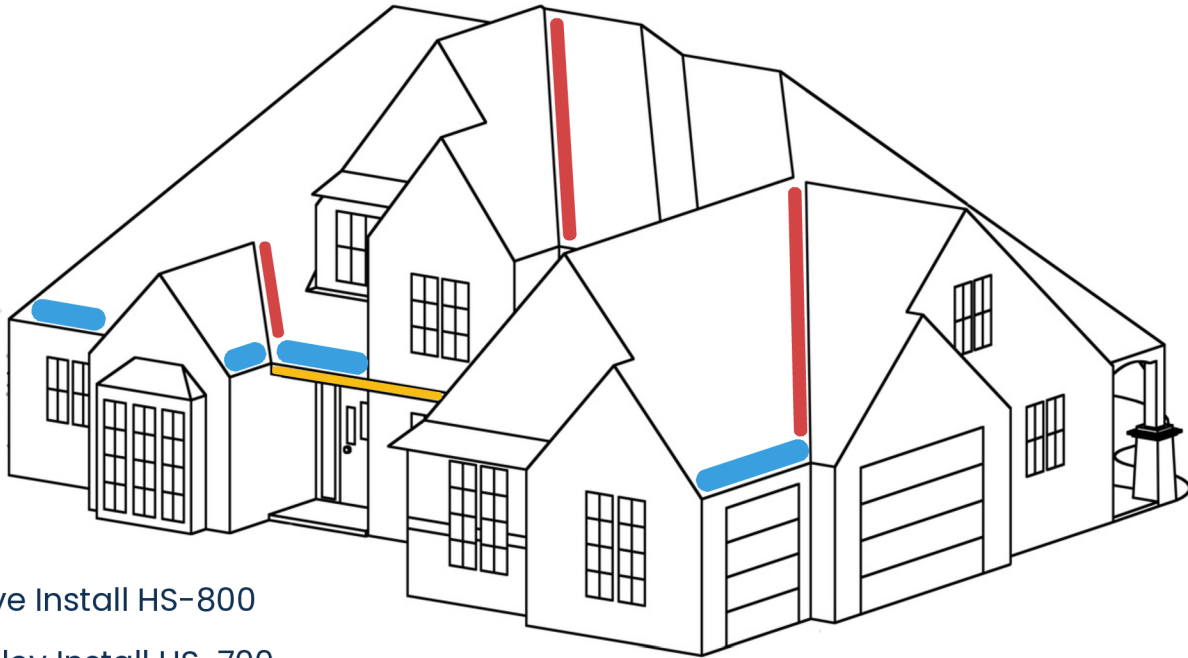

- Eave Install HS-800
- Valley Install HS-700
- Gutter Install HS-700

ROOF TYPES

- Asphalt Shingle
- Synthetic Slate or Shake

LAYOUT OVERVIEW FOR STEEP SLOPE APPLICATIONS:

- HeatDefender cable concealer should be installed at the roof edge.
- Eave base extrusion should be fastened to the roof rafters when possible.
- If a rafter is not available for all fasteners in a base extrusion run, use fasteners with threads that will engage the roof substrate.
- When installing HeatDefender, consider the heat cable's minimum radius and space components to avoid damaging the heating cable.
- The HeatDefender and coordinating heat cable must be installed correctly to ensure proper operation and prevent shock and fire.
- The installer must follow all safety requirements established in the heat cable and controller manufacturer's installation instructions and product specifications.
- Flashing can be cut and matched to create a continuous, seamless cover for the entire heat trace run.
- A continuous run of heating cable is required from the roof to the landscaping.

HeatDefender Steep Slope Applications

Our rigorous climate chamber testing, conducted in partnership with Microclimate Ice & Snow Inc., has transformed how we approach roof de-icing. While traditional "cable-only" installations lose significant heat to the surrounding air, the HeatDefender's two-part aluminum extrusion acts as a high-efficiency thermal radiator. The aluminum housing captures and distributes heat across its entire surface, significantly increasing the effective snowmelt area compared to exposed cables. This maximized radiant heat maintains wide, reliable drainage channels, keeps roof edges clear, and actively prevents hazardous ice dams.

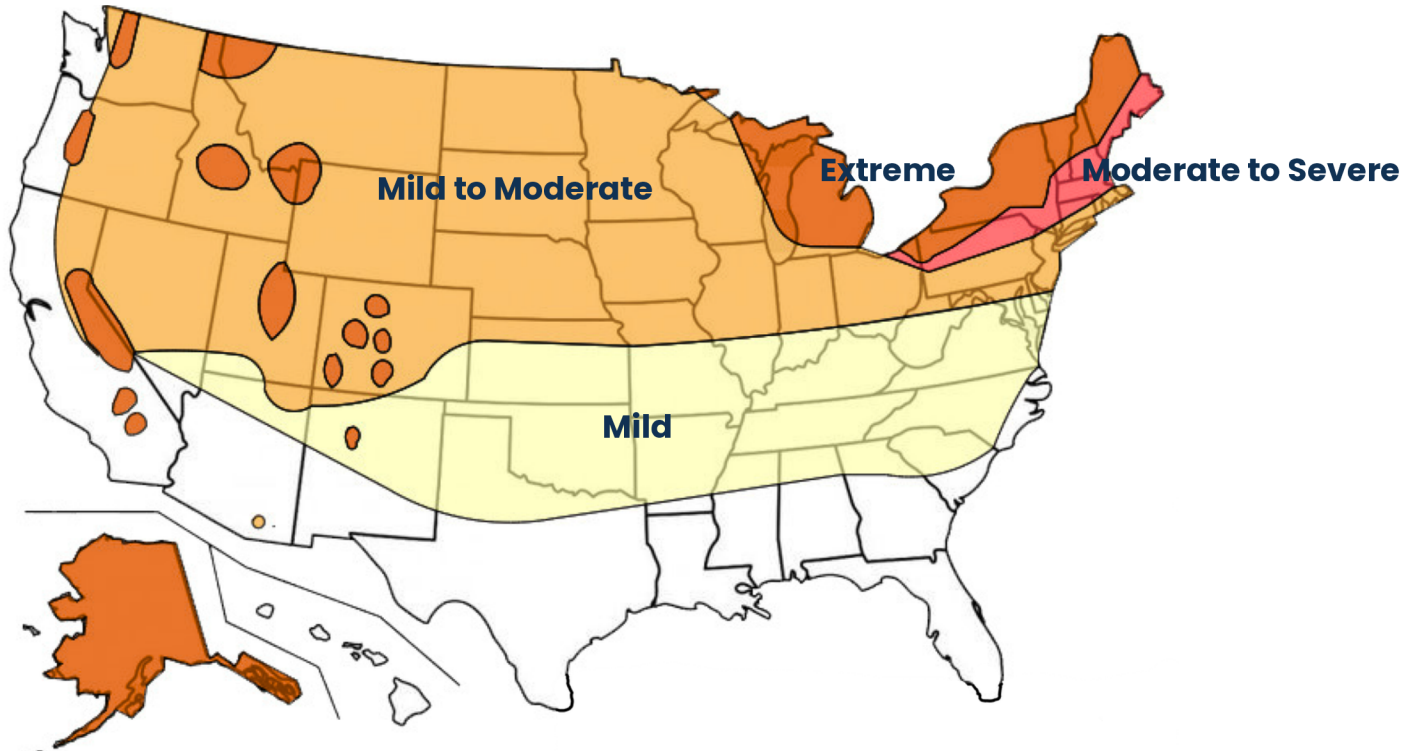

PROJECT HARDWARE AND WATTAGE RECOMMENDATIONS BY ANNUAL SNOWFALL:

Risk Category	Annual Snowfall	Roof Accumulation	Recommended HeatDefender & Cable Wattage
I: Mild	0" – 24"	Typical accumulations of 6" or less most of the winter	HS-700 (Valleys/Gutters >6"): Min. 16 W/ft HS-800 (Eave edge): Min. 16 W/ft
II: Mild to Moderate	>24" – 48"	Typical accumulations of 12" on the roof for most of the winter	HS-700 (Valleys/Gutters >6"): Min. 16 W/ft HS-800 (Eave edge): Min. 16 W/ft
III: Moderate to Severe	>48" – 84"	12" – 15" of snow on the roof for most of the winter	HS-700 (Valleys/Gutters >6"): Min. 20 W/ft HS-800 (Eave edge): 20 W/ft
IV: Extreme	>84"	Greater than 15" of snow on the roof for most of the winter	HS-700 (Valleys/Gutters >6"): Min. 20 W/ft HS-800 (Eave edge): 30 W/ft

TEMPERATURE OVERRIDE RULE: Extreme cold rapidly pulls heat away from all heat cables. If your project is in a region where mean low winter temperatures regularly drop below 15°F (-9°C), or is subject to high winter wind exposure, you must step up to the 20 to 30 W/ft configurations to ensure the system does not freeze over, regardless of your snow accumulation zone.

Cable Configurations

The HeatDefender system is engineered to maximize the thermal potential of self-regulating cables by transforming the aluminum housing into a high-efficiency radiator. While traditional cables provide only a narrow melt path, the HeatDefender distributes heat across the entire width of the extrusion, maintaining wide, reliable drainage channels even in extreme environments. It keeps roof edges clear and actively prevents hazardous ice dams.

HS-800



Two Cables

High output. 2 outer channels used, minimum 16-30 watts/ft. Melt path width 8-10".



Three Cables

Extreme output. 3 channels used, minimum 24-30 watts/ft. Melt path width 10-12".



HS-800 + Flashing

Extreme output plus. 2-3 channels used, minimum 16-30 watts/ft. Melt path up to 14".

HS-700



Two Cables

Full heat. 2 channels used, minimum 16-20 watts/ft. Melt path width 6-8".



All Systems

A continuous melt path must be obtained. The cable should be installed on the eave, gutter, and continue into the landscaping or drainage system below the frost line.

SYSTEM	CHANNELS USED	MELT PATH WIDTH	PRIMARY APPLICATION
HS-700	2 Channels	6" to 8"	Valleys and standard gutters.
HS-800	2 (Outer) Channels	8" to 10"	Standard residential eave de-icing .
HS-800	3 (Full) Channels	10" to 12"	Severe cold and commercial gutters.
HS-800 + Flashing	2 or 3 Channels	Up to 14"	Premium shingle eave de-icing with HS-802-FL.

HeatDefender Steep Slope Applications

Eave

BILL OF MATERIALS

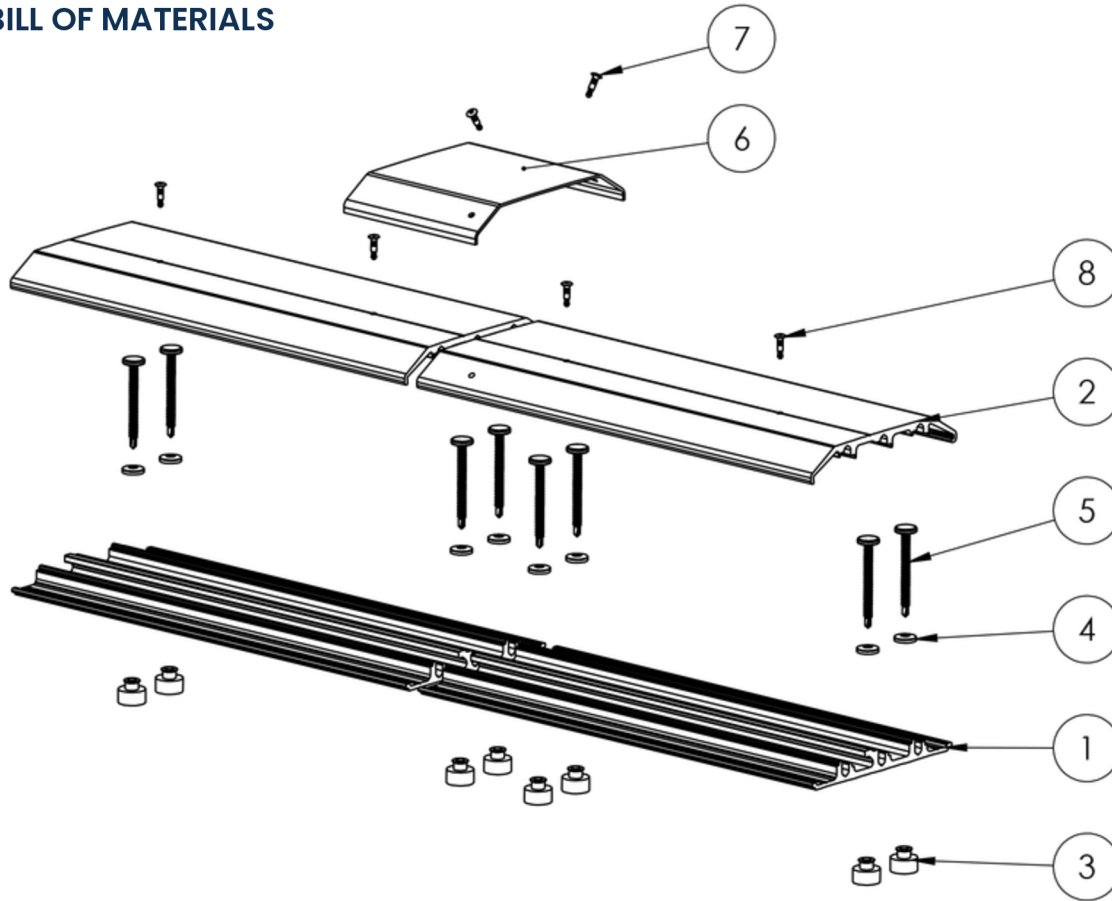

ITEM	PART NUMBER	DESCRIPTION	REQUIRED QTY
1	HS-801 / HS-701	HD Base (6' Length)	As Needed
2	HS-802 / HS-702	HD Cover (6' Length)	As Needed
3	B-100-S	EPDM Bushing (.203 x .625)	8 per Base
4	W-NEO SS-.25	SS Neo Bonded Washer	8 per Base
5	#10 Woodscrew	Mounting Fastener (Customer Supplied)	8 per Base
6	HS-803-C	Extrusion Coupling	As Needed
7	HS-802-FL	HD Kynar Flashing (6' Lengths)	As Needed
8	.125" Rivet	Housing & Coupling Rivet (Customer Supplied)	As Needed

HeatDefender Steep Slope Applications

HeatDefender components are modular and can be installed independently as needed for eave, valley, or gutter-only applications. Visit alpinesnowguards.com for full installation instructions by roof type and HeatDefender product.

DESIGN & SPECIFICATION SUMMARY: ATTACHMENTS, ROUTING, AND INTEGRATION

GENERAL FASTENING & QUALITY ASSURANCE

- **Mechanical Fasteners:** Where mechanical attachment is required, specify #10 Woodscrews with W-NEO (neoprene) washers.
- **Installation Tolerances (Torque):** Proper seal integrity relies on exact torque. Washers must be compressed flat for a uniform weather seal. Specify that over-torqued (cupped/deformed washers) or under-torqued (loose washers) installations are unacceptable and must be corrected to prevent water penetration.
- **Pre-Cover Testing:** Specifications must mandate that the electrical insulation and resistance of the heating cables be tested and verified (per the cable manufacturer's guidelines) before the final flashing and covers are installed.

HS-700 VALLEY SYSTEM (ADHERED APPLICATION)

- **Positioning:** The valley base must be offset a minimum of 1/8" from the valley "V" crimp to ensure the cover panel seats precisely.
- **Adhesive Attachment:** Valley bases are specified as a fully adhered system; no mechanical fasteners are required. Substrates must be prepared with a solvent cleaner (e.g., denatured alcohol) prior to the application of continuous beads of manufacturer-approved adhesive along both sides of the base.

SYSTEM TRANSITIONS & TERMINATIONS

- **Eave-to-Valley Transitions:** Components must be spaced appropriately to accommodate seamless cable routing. The design must respect the exact minimum bend radius specified by the heating cable manufacturer to prevent cable damage.
- **Cable Loops/Returns:** At the termination of an extrusion run where the cable loops back, specify a Cable Return Hollow Base (HS-800-H). A minimum 3/8" gap must be maintained between the return base and the primary HS-800 base to accommodate the cable loop.

HeatDefender Steep Slope Applications

GUTTER & DOWNSPOUT INTEGRATION

- **Profile Sizing:** Specify the HS-700 base for standard gutters up to 6 inches wide. For high-capacity gutters exceeding 6 inches in width, specify the HS-800 base.
- **Gutter Placement:** Bases are designed to be placed directly inside the gutter. Mechanical or adhesive attachment is not required unless the project is located in a specified high-wind zone.
- **Downspout Routing:** To ensure proper meltwater drainage, specify that heating cables must run continuously through the downspouts. If the downspouts tie into an underground drainage system, the cable must extend below the local frost line.

FLASHING SYSTEM OVERVIEW

Once the heat cables are routed within the base channels, the system is enclosed using protective covers. The assembly can be specified in three primary configurations depending on the roof condition and location: Non-Flashed (HS-800), Flashed (HS-801), or Valley Flashing (HS-700). All components are engineered to provide weatherproofing, aesthetic continuity, and structural integrity.

HS-800 System (Non-Flashed)

- **Assembly:** Covers and hollow cable returns are mechanically secured (riveted) to the base extrusion at specified intervals.
- **Continuous Runs:** For multi-section profiles, joints are seamlessly connected and secured using designated Couplings (HS-803-C).
- **Terminations:** System ends are closed off using End Caps (HS-800-END), which include rubber weather-plugs to seal off any unused wire routing slots.

HS-800 System (Flashed via HS-802-FL)

- **New Construction:** The flashing is fastened and sealed to the roof deck/extrusion first, and the upper course of roofing shingles is installed directly over the flashing flange to maintain proper weather lapping.
- **Retrofit / Existing Roofs:** The system is designed so the flashing flange can be retrofitted seamlessly under the existing upper course of shingles, preserving the integrity of the existing roof envelope.

HeatDefender Low Slope Applications

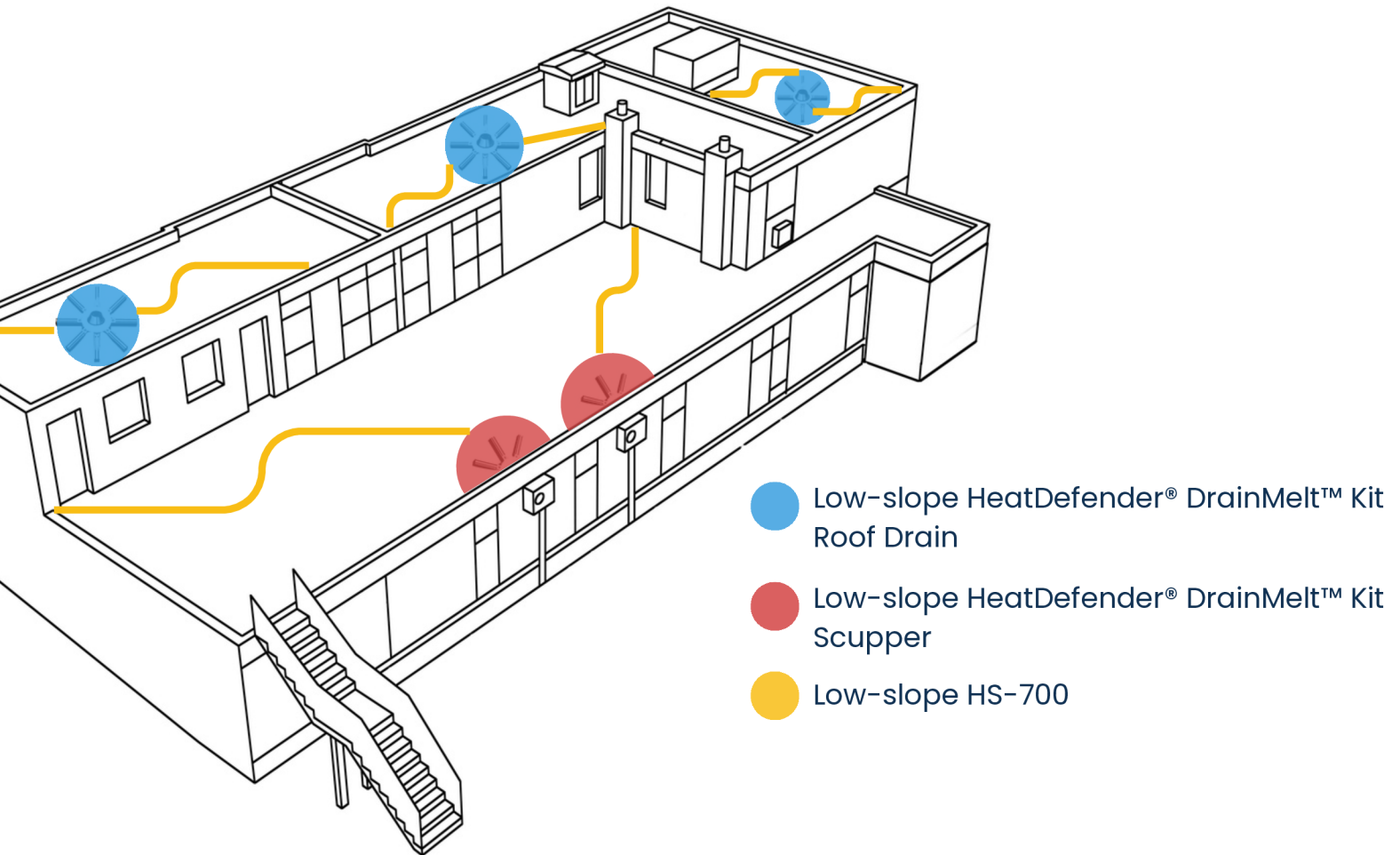

- Low-slope HeatDefender® DrainMelt™ Kit Roof Drain
- Low-slope HeatDefender® DrainMelt™ Kit Scupper
- Low-slope HS-700

The HeatDefender® DrainMelt™ Kit is a heavy-duty aluminum housing solution designed to keep roof drains and scuppers clear of ice and snow (self-regulating heating cable sold separately). The system utilizes a radial or linear "spoke" design to transfer heat efficiently to the drainage area.

ROOF TYPES

- Membrane (EPDM, PVC, TPO)

LAYOUT OVERVIEW

- The system uses the HeatDefender Drain Template to set fixed layouts for specific drain sizes (8" to 18") and scuppers (up to 24"). This removes manual measurement and ensures symmetrical spacing to prevent cold spots.
- The HS-701/702 base and cover are sized as an "open platform." The internal dimensions accommodate the varying widths and bend radii of three different self-regulating cable manufacturers.



HeatDefender Low Slope Applications

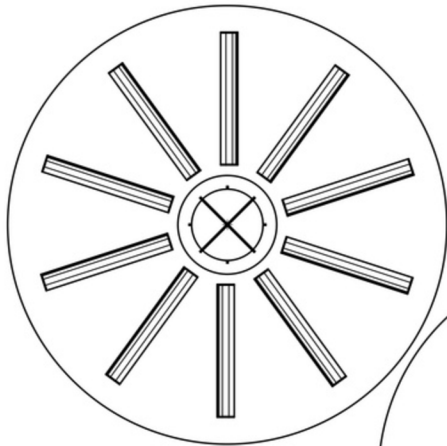

HeatDefender® DrainMelt™ 18
Accommodates standard 18"+ drains

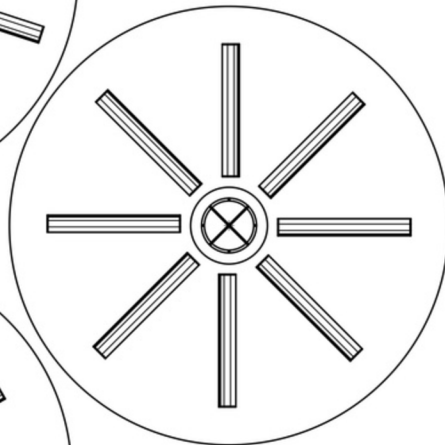

HeatDefender® DrainMelt™ 16
Accommodates standard 12-16" drains

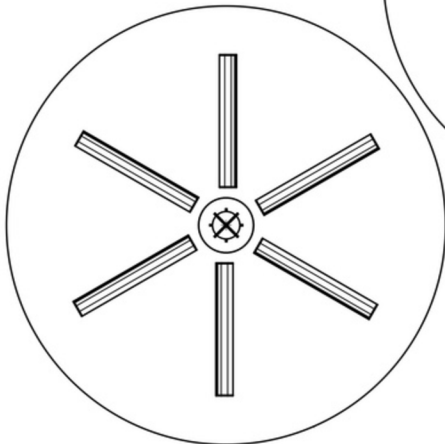

HeatDefender® DrainMelt™ 10 Accommodates standard 8-10" drains

KIT CONFIGURATIONS & LAYOUTS

Select the appropriate kit based on the diameter of your drain or the width of your scupper:

MODEL	DRAIN DIAMETER	SCUPPER WIDTH	COMPONENT QUANTITY	LAYOUT PATTERN
HeatDefender® DrainMelt™ 10	8-10"	Up to 10" wide	QTY 6 2' Bases and Covers	6-Spoke Radial or Fan
HeatDefender® DrainMelt™ 16	12-16"	Up to 16"	QTY 8 2' Bases and Covers	8-Spoke Radial or Fan
HeatDefender® DrainMelt™ 18	18"+	18" or greater	QTY 10 2' Bases and Covers	10-Spoke Radial or Fan

Note: HeatDefender® DrainMelt™ products are mechanical housing kits. Kits include aluminum bases, aluminum covers, layout templates, and end caps. Self-regulating heat trace cable and electrical connections are not included and must be sourced separately.

HeatDefender Low Slope Applications

DESIGN & SPECIFICATION SUMMARY: LOW-SLOPE DRAIN AND SCUPPER HEATING SYSTEMS

GENERAL REQUIREMENTS & QUALITY ASSURANCE

- **Membrane Compatibility & Preparation:** The extrusion base is designed as a fully adhered system to preserve the integrity of the low-slope roof envelope. Specifications must dictate that the roof surface (TPO, EPDM, PVC, etc.) be prepped and cleaned per the specific membrane manufacturer's requirements to ensure proper chemical adhesion.
- **Electrical Compliance:** The system components house electrical devices. Specify that ground-fault equipment protection (GFEP) must be utilized on every heating cable branch circuit. All final electrical connections must be completed by a licensed electrician.
- **Component Protection:** Specifications must require that heating cables be kept dry before and during installation, and that installers adhere to the manufacturer's handling guidelines to prevent damage to the bus wire strands or cable core.

ROOF DRAIN INTEGRATION (RADIAL CONFIGURATION)

- **Layout Intent:** For standard low-slope roof drains, specify a radial "spoke" layout using 2-foot lengths of HS-701 Bases configured around the drain (utilizing the HeatDefender® DrainMelt™ Layout Template).
- **Adhered Attachment:** The HS-701 Base sections are strictly secured using structural adhesive (Chemlink is recommended). Specify two continuous ¼" thick beads of adhesive per base, inset ½" from the edges to prevent squeeze-out. Critical Note: Adhesive must be allowed to fully cure per the manufacturer's guidelines prior to cable installation.
- **Routing & Assembly:** Self-regulating heating cable is routed through the base channels, looping at the outer spoke ends, and must run down directly into the roof drain bowl to maintain an open melt-path.
- **Enclosure:** HS-702 Covers are mechanically engaged and riveted to the bases. The outer termination of each spoke is sealed with an adhesively applied End Cap.

SCUPPER INTEGRATION (FAN CONFIGURATION)

- **Layout Intent:** For parapet scuppers, specify a "fan" pattern layout using the HS-701 Bases, angled to deliberately channel meltwater toward the wall opening.
- **System Sizing:** * For scuppers up to 14 inches wide: Specify the HeatDefender® DrainMelt™ 10 Kit (includes 6 sections).
- For scuppers up to 24 inches wide: Specify the HeatDefender® DrainMelt™ 16 Kit (includes 8 sections).
- **Wall Transition Routing:** Ensure drawings and specifications mandate that at least one continuous run of heating cable extends directly through the scupper opening and down into the adjoining conductor head or downspout to prevent ice blockages at the transition.

SYSTEM COMMISSIONING

Final Testing: Project specifications must require a documented final power test, performed by a licensed electrician, to verify consistent heat output across all system spokes/sections and entirely through the final drainage exit.

Technical Details

RIVET REFERENCE TABLE

Application	Rivet Cinch Length	Location
End Hollow Base to Cover	.209"	2 per cover (1 upslope, 1 downslope)
HS-800 Base to Cover	.349"	2 per cover on marked line
Coupling or End Cap	.183"	2 on one side (left or right)
Base, Cover, and Flashing	.349" + Flashing	2 per run on upslope side

MECHANICAL FASTENER TORQUE REFERENCE

- Fastened Correctly: Washer is flat and compressed for a uniform seal.
- Over-Torqued: Washer is "cupped" or deformed; seal is compromised.
- Under-Torqued: Washer is loose; water will penetrate.

MAINTENANCE

- Annual Check: Clear leaves and debris from housing and gutters every fall.
- Refer to cable manufacturers' instructions for winter startup and spring seasonal shutdown procedures.
- Intermittent Winter Checks: Check all roof and drainage surfaces for water ponding or drainage issues throughout the winter season, ensuring the system is performing as intended, and there are no debris or ice blockages.

PART 1 – GENERAL

1.1 SUMMARY

A. WORK INCLUDES

1. HeatDefender® high-performance heat trace cable concealer system attaches directly to roof deck, gutter, valley, or low-slope drainage area.
2. Coordinate with the roofing material installation to ensure proper placement of heat trace cable.
3. Provide appropriate concealed heat trace cable components; fasteners and adhesives shall be sourced separately by the installing contractor.

B. RELATED SECTIONS – MasterFormat 2016

1. Section 077100: Roof Specialties	MasterFormat	2016	07	70	00
2. Section 077123: Gutters and Downspouts	MasterFormat	2016	07	71	00
3. Section 077200: Roof Accessories	MasterFormat	2016	07	70	00
4. Section 221426.13: Roof Drains	MasterFormat	2016	22	14	00
5. Section 073100: Shingles and Shakes	MasterFormat	2016	07	30	00
6. Section 073200: Roof Tiles	MasterFormat	2016	07	30	00
7. Section 074200: Wall Panels	MasterFormat	2016	07	40	00
8. Section 074400: Faced Panels	MasterFormat	2016	07	40	00
9. Section 076000: Flashing and Sheet Metal	MasterFormat	2016	07	60	00

1.2 SYSTEM DESCRIPTION

A. COMPONENTS

HeatDefender® uses aluminum extrusions to house and protect heat-trace cables, enhancing performance in roof, gutter, and low-slope roof drainage de-icing applications. Mechanically attached configurations use a bushing for watertight attachment to the roof deck. An additional flashing system for shingle roof applications is available.

1. HS-800 3 cable system – Eave Heat Trace Cable Concealer, a 5" wide, up to 3 heating cable run system
 - a. HS-801 Base of 3 cable housing (choose one)
 - i. Cable channels to fit Raychem GMX1 & GMX2
 - ii. Cable channels to fit Chromalox CPR8, CPR10 & CPR15, and Thermon RGS
 - b. HS-802 Cover of 3 cable housing
 - c. HS-803-C Coupling for 3 cable housing (not required when installed with HS-802-FL)
 - d. HS-800-END HOLLOW (includes HS-801-H and HS-802-H components)
 - i. HS-801-H End Cable Return Hollow Base for 3 cable housing
 - ii. HS-803-H End Cable Return Hollow Cover for 3 cable housing
 - e. HS-802-FL Cover flashing for shingle roofing (optional)
 - f. HS 800-END 3 cable end assembly (optional)
 - g. HS-800-EP plugs for 3 cable end assembly(optional)
2. HS-700 2 cable system – Eave, Gutter or Valley Heat Trace Cable Concealer, a 3.125" wide, up to 2 heating cable run system
 - a. HS-701 Base of 2 cable housing (choose one)
 - i. Cable channels to fit Raychem GMX1 & GMX2
 - ii. Cable channels to fit Chromalox CPR8, CPR10 & CPR15, and Thermon RGS
 - b. HS-702 Cover of 2 cable housing

HeatDefender

3 PART SPECIFICATION

3. BUSHING B-100-S bushing for compression-fit seal at roof attachment points must be used with HS-801 and HS-701 when mechanically fastened. Not applicable for adhered applications.
4. W-NEO SS-.25 bonded washer to be used with HS-BUSHING for sealing mechanical attachment.
5. HeatDefender DrainMelt Kits – 3 different drain sizes available (uses HS-700 2 cable system), a 3.125" wide extrusion cut to 2' sections and positioned around the drain in a spoke or fan pattern.
 - a. HS-DRAIN10IN-KIT
 - i. HS-701, QTY 6 Base of 2 cable housing (choose one)
 1. Cable channels to fit Raychem GMX1 & GMX2
 2. Cable channels to fit Chromalox CPR8, CPR10 & CPR15, and Thermon RGS
 - ii. HS-702, QTY 6 Cover of 2 cable housing
 - iii. HS-DRAIN-END CAP, QTY 12
 - iv. HS-DRAIN10-TEMPLATE, QTY 1 (installation tool only)
 - b. HS-DRAIN16IN-KIT
 - i. HS-701, QTY 8 Base of 2 cable housing (choose one)
 1. Cable channels to fit Raychem GMX1 & GMX2
 2. Cable channels to fit Chromalox CPR8, CPR10 & CPR15, and Thermon RGS
 - ii. HS-702, QTY 8 Cover of 2 cable housing
 - iii. HS-DRAIN-END CAP, QTY 16
 - iv. HS-DRAIN16-TEMPLATE, QTY 1 (installation tool only)
 - c. HS-DRAIN18IN-KIT
 - i. HS-701, QTY 10 Base of 2 cable housing (choose one)
 1. Cable channels to fit Raychem GMX1 & GMX2
 2. Cable channels to fit Chromalox CPR8, CPR10 & CPR15, and Thermon RGS
 - ii. HS-702, QTY 10 Cover of 2 cable housing
 - iii. HS-DRAIN-END CAP, QTY 20
 - iv. HS-DRAIN18-TEMPLATE, QTY 1 (installation tool only)

Fasteners (not supplied):

- a. To be of metal compatible with HeatDefender Heat Trace Cable Concealer systems.
- b. Fasteners should be selected for compatibility with roof deck.
- c. Fastener strength should exceed or equal that of the Heat Defender Heat Trace Cable Concealer systems.

B. DESIGN REQUIREMENTS

1. System layout is to be recommended by the manufacturer, building engineer, or electrician.
2. System layout must provide a continuous warm path from HeatDefender to final melt water outlet at landscape.
3. Install two fasteners per 2' of HeatDefender® base when mechanically fastened to roof deck (not applicable for non-penetrating adhered low-slope membrane applications).
Install three fasteners per End Cable Return Hollow base.
4. Install 2 rivets per Coupling on one side (left or right) of the extrusion. Install 2 rivets per 6' run into the HeatDefender cover on the upslope side. Install 2 rivets per 8' run into Flashing if using optional flashing.

HeatDefender

3 PART SPECIFICATION

5. HeatDefender Heat Trace Cable Concealer requires a self-regulating heating cable.
A plug-in constant-watt heat trace cable is not acceptable.
6. A self-regulating heating cable must be a two-conductor system, meaning the cable does not have to return to its start point. One-conductor cables are not acceptable for this application.
7. A heating cable with an outer polyolefin jacket is required. Cables without an outer jacket are not for wet applications and, therefore, cannot be used in this application.
8. The heating cable must allow the installer to cut to length in the field without developing cold zones. Heat trace cable systems that cannot be cut to length are unacceptable for this application.
9. Self-regulating heating cable must be installed with a system controller capable of managing the length and wattage of heat trace cable used.

1.3 SUBMITTAL

- A. Submit manufacturer's specifications, standard detail drawings, and installation instructions.

1.4 QUALITY ASSURANCE

- A. Installer must have at least five years' experience installing roof heat trace systems in the project area.
- B. A licensed electrician shall complete all electrical rough-ins and connections required to install the system.

1.5 DELIVERY / STORAGE / HANDLING

- A. Inspect material upon delivery and order replacements for any missing or defective items. Keep material dry, covered, and off the ground until installed.

PART 2 – PRODUCTS

2.1 MANUFACTURER

- A. Alpine SnowGuards®, a Division of Vermont Slate & Copper Services, Inc.
289 Harrel St., Morrisville, VT 05661 | 888-766-4273 | www.alpinesnowguards.com

2.2 MATERIALS

- A. HS-801 – 6000 series aluminum
- B. HS-802 – 6000 series aluminum
- C. HS-803-C – 6000 series aluminum
- D. HS-801-H – 6000 series aluminum
- E. HS-803-H – 6000 series aluminum
- F. HS-802-FL – .032 3000 series aluminum
- G. HS-802-FL-C – .032 3000 series aluminum
- H. HS-800-END – 6000 series aluminum
- I. HS-800-EP – EPDM rubber
- J. HS-701 – 6000 series aluminum
- K. HS-702 – 6000 series aluminum
- L. BUSHING B-100-S – EPDM rubber
- M. W-NEO SS-.25 – neoprene and stainless steel
- N. HS-DRAIN-END CAP – TPU
- O. HS-DRAIN(10,16,18)-TEMPLATE- 5000 Series Aluminum (installation tool only)

2.3 FINISH (choose one)

6000 series aluminum components:

- A. Mill Finish – standard
- B. Powder Coated – optional and available at additional cost (HS-DRAIN Kits, HS-702 is powder-coated, no additional cost)

.032 3000 series aluminum components:

- A. Kynar 500® pre-painted coil

PART 3 – EXECUTION

3.1 EXAMINATION

A. Substrate

1. Inspect the structure on which HeatDefender is to be installed and verify it will allow the system to be securely fastened. Notify general contractor of any deficiencies before installing Alpine SnowGuards' products.
2. Verify roofing material has been installed correctly before installing HeatDefender.

3.2 INSTALLATION

- A. Comply with architectural drawings and heat trace cable manufacturer's recommendations for the location of the system. Comply with the manufacturer's written installation instructions for installation.
- B. A complete installation must conform to the appropriate manufacturer's instructions, the National Electrical Code, and the relevant local codes.

Document Version 05.19.26